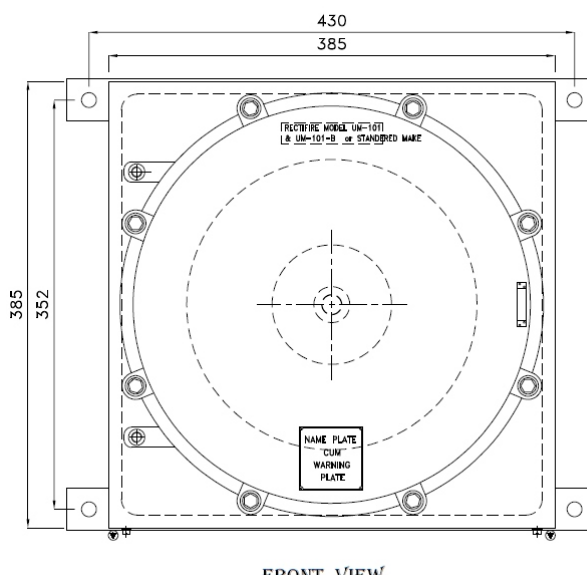

**DATA SHEET FOR FLP ELECTRO MAGNETIC BRAKE****TECHNICAL DATA:**

PRODUCT	: CAT NO: BR / 2C / 2027A
ENCLOSURE	: FLAME PROOF (Ex -d), Gas Group IIA , IIB , IIC As per IS/IEC 60079-1 : 2014
PROTECTION	: WEATHER PROOF IP – 65 AS PER IS/IEC 60529:2001 (Reaffirmed 2014)
AREA & TEMP. CLASS	: Ex db IIC T6 Gb (EX tb/tc IIIC T85 C Db/Dc (ZONE 1 & 2 & Zone 21 & 22)
CERTIFICATION	: CIMFR, BIS, PESO
TEMPERATURE CLASS	: T6
MATERIAL	: CAST ALUMINIUM ALLOY
FINISH	: EPOXY POWDER COATED SHADE AS PER IS : 5
EARTHING	: 1 No INTERNAL & 2 No's EXTERNAL
HARDWARE	: STAINLESS STEEL
GASKET	: 'O' RING ENDLESS GASKET NEOPRENE / SILICON
NAME PLATE	: SS NAME PLATE CUM WARNING PLATE
INPUT VOLTAGE	: 415 V AC , 3 PHASE , 50 HZ.
OUTPUT VOLTAGE	: 190 – 220 VOLTS
RATING	: 800 N/m (NEWTON METRE) TORQUE
TERMINAL ENTRIES	: 4 NOS OF 2.5 SQ.MM CLIP ON TYPE TERMINALS. 2 Nos M20 / ½ " NPT / EQUIVALENT UPTO M 25

OPTIONS

SR.NO	PARTICULAR	OPTIONS
1.	GLAND & PLUG	BRASS / SS / ALUMINIUM
2.	COLOUR SHADE	631, 632, 355, 7031, 7032 etc.

**Specification :**

Break Rating	: Max. upto 800 N/m (Newton Metre) Torque,
Input Current	: 1-3 Amp.
Input Voltage	: 415 Volts
Output Voltage	: 190-220 Volts